

MODEL P.025 METAL PUMP STAINLESS

仕様 / Specifications

- 全高 / HEIGHT ----- 148 mm
- 全幅 / WIDTH ----- 170 mm
- 奥行き / DEPTH ----- 114 mm
- 重量 / SHIP WEIGHT ----- 4.0 kg
- 圧縮空気入口 / AIR INLET ----- FNPT1/8"
- 排気口 / AIR EXHAUST -----
- 吸込口 / SUCTION ----- Rc1/4"
- 吐出口 / DISCHARGE ----- Rc1/4"

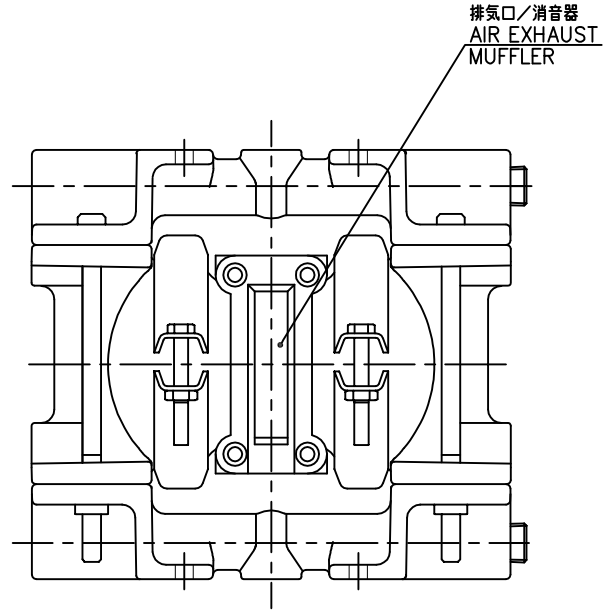
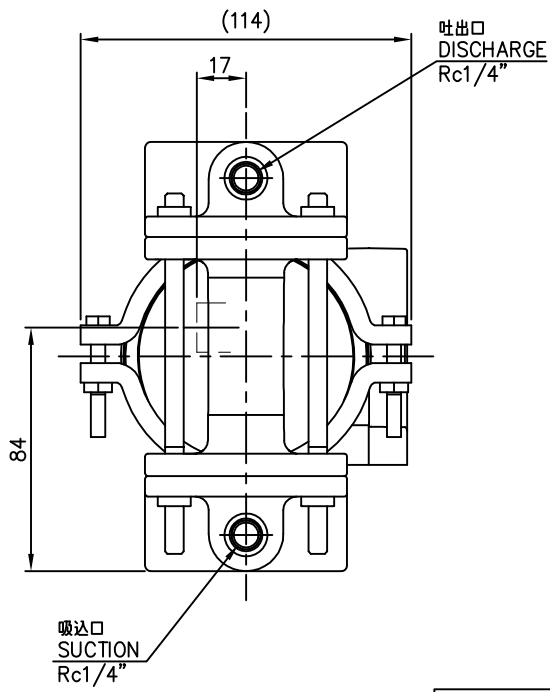
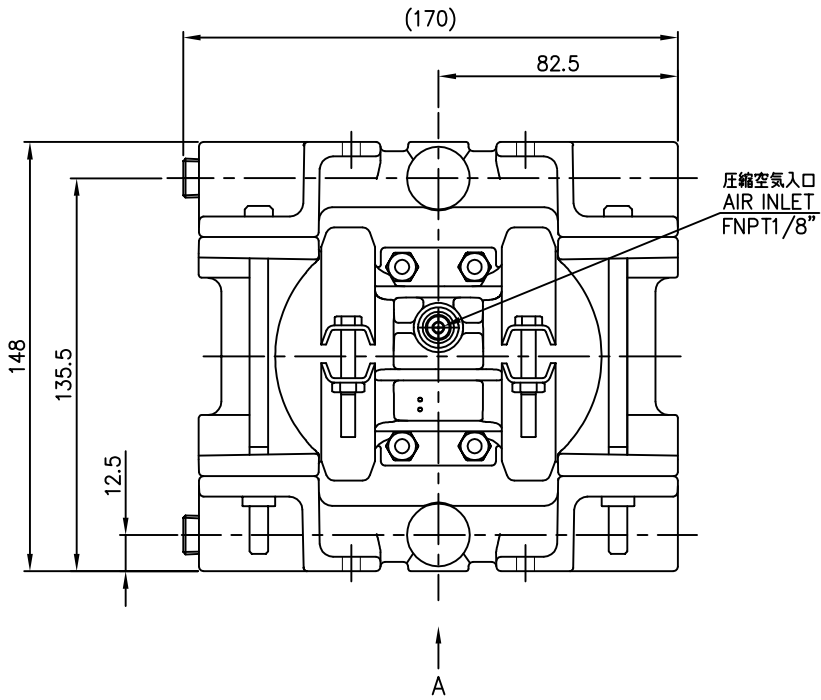
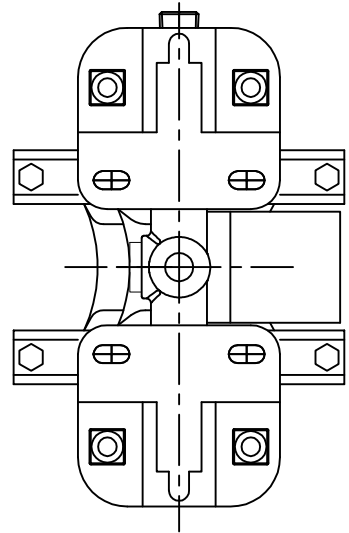
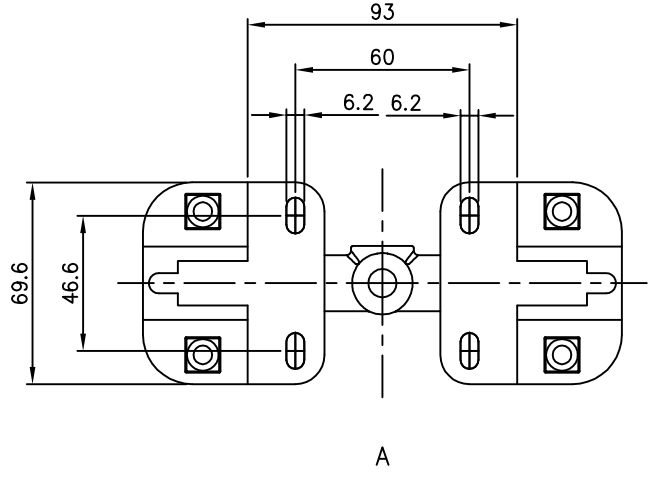

MATERIAL ---	DES. BY			TITLE エアー式ダブルダイアフラムポンプ	
SCALE (A3) 1 : 2	DWG. BY <i>D.Sugiyama</i> 20/05/29	APP. BY	WILDEN AIR OPERATED DOUBLE DIAPHRAGM PUMP		
UNITS	JAPAN MACHINERY COMPANY			型式 / MODEL: P.025 STAINLESS	
				DRAWING NO. P.025型 (1/4") SUS316	REV. MARK 0