

MODEL P.025 METAL PUMP ALUMINIUM

仕様 / Specifications

全高 / HEIGHT	-----	148 mm
全幅 / WIDTH	-----	167 mm
奥行き / DEPTH	-----	115 mm
重量 / SHIP WEIGHT	-----	1.9 kg
圧縮空気入口 / AIR INLET	-----	FNPT1/8"
排気口 / AIR EXHAUST	-----	
吸込口 / SUCTION	-----	Rc1/4"
吐出口 / DISCHARGE	-----	Rc1/4"

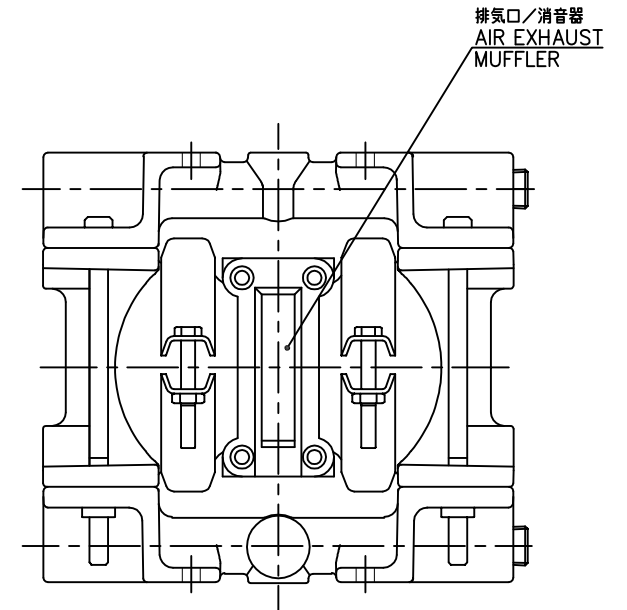
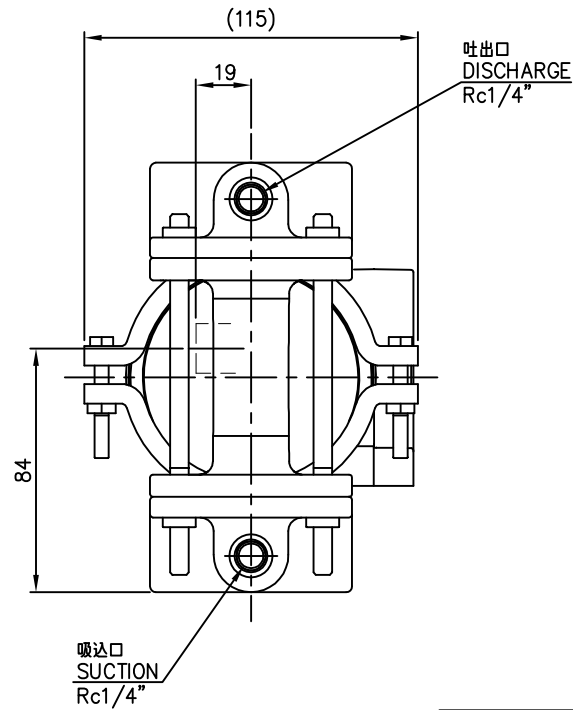
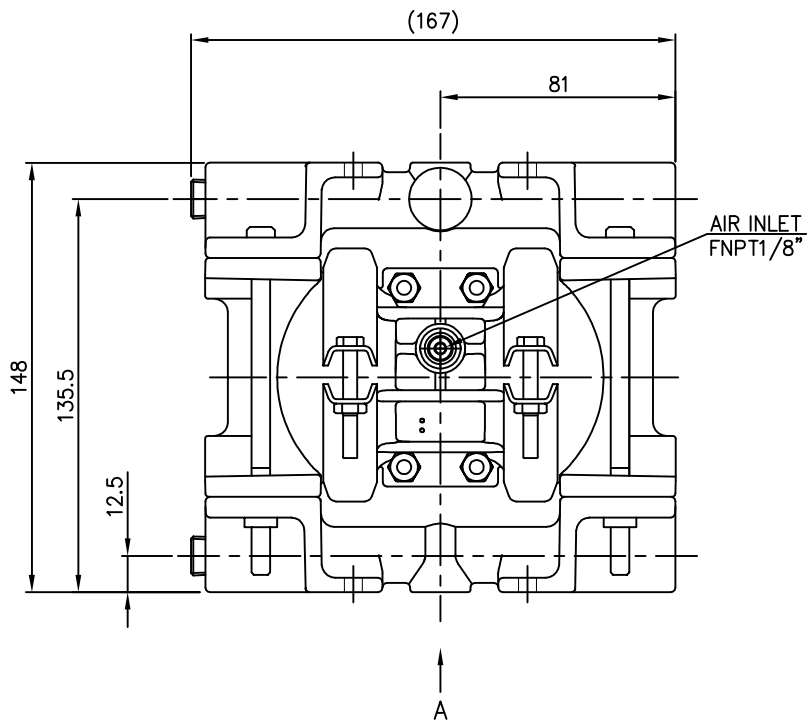
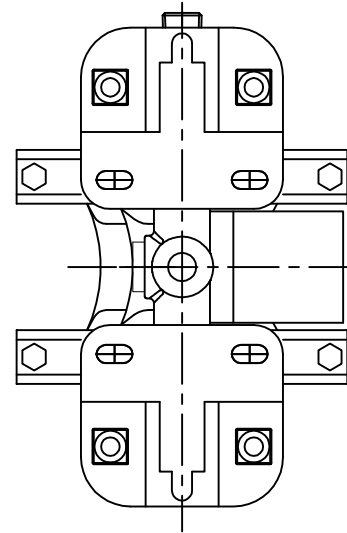
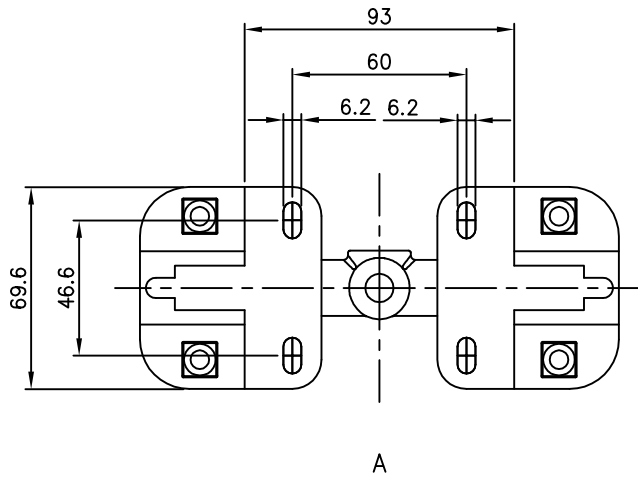

MATERIAL ---	DES. BY		APP. BY	TITLE エアー式ダブルダイヤフラムポンプ WILDEN AIR OPERATED DOUBLE DIAPHRAGM PUMP 型式/MODEL: P.025 ALUMINIUM
SCALE (A3) 1 : 2	DWG. BY <i>D.Sugiyama</i> 20/05/29			
UNITS	JAPAN MACHINERY COMPANY		DRAWING NO. P.025型 (1/4") アルミニウム	
				REV. MARK 0