

MODEL XPS1 METAL PUMP ALUMINUM

仕様 / Specifications

全高 / HEIGHT	-----	223 mm
全幅 / WIDTH	-----	207 mm
奥行 / DEPTH	-----	353 mm
重量 / SHIP WEIGHT	-----	5.5 kg
圧縮空気入口 / AIR INLET	----	FNPT1/2"
排気口 / AIR EXHAUST	----	FNPT1/2"
吸込口 / SUCTION	-----	Rc1/2"
吐出口 / DISCHARGE	-----	Rc1/2"

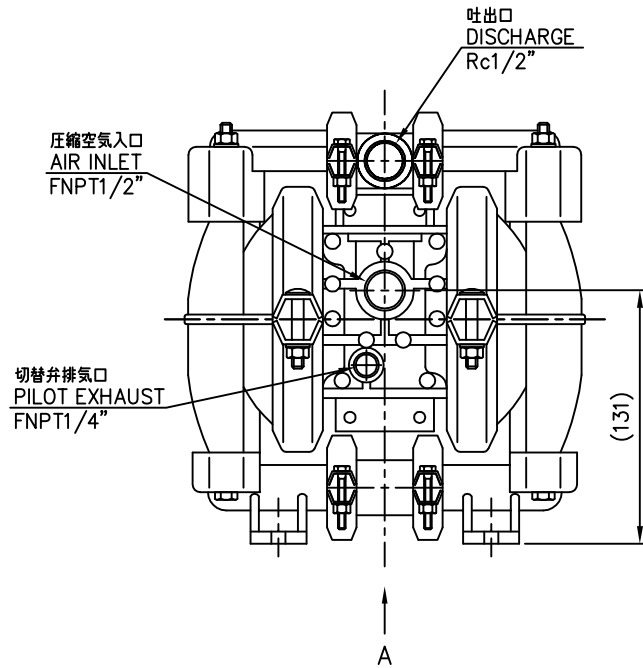
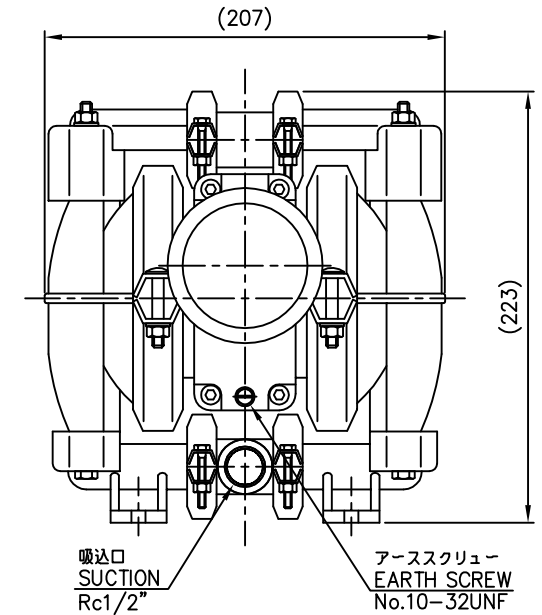
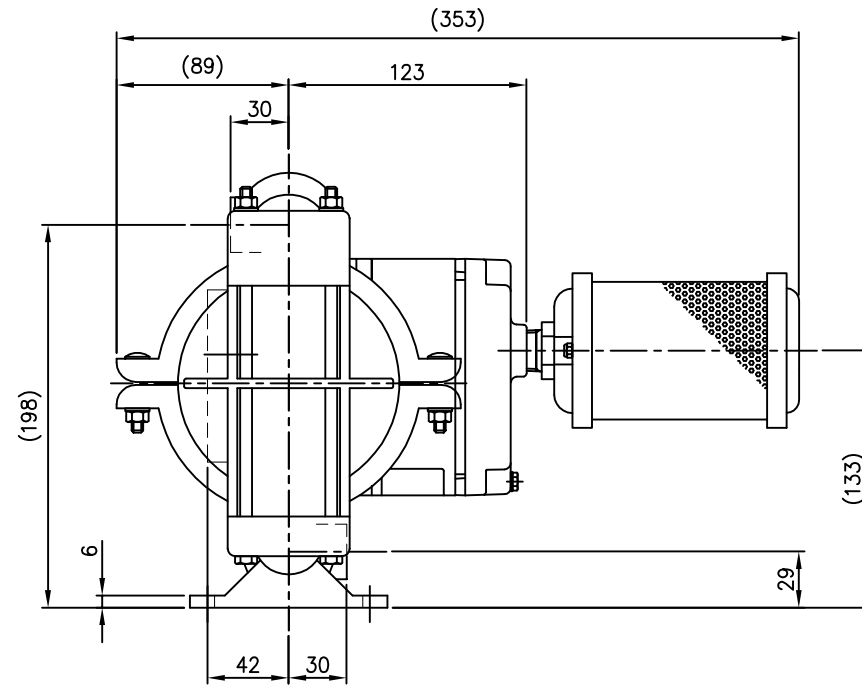
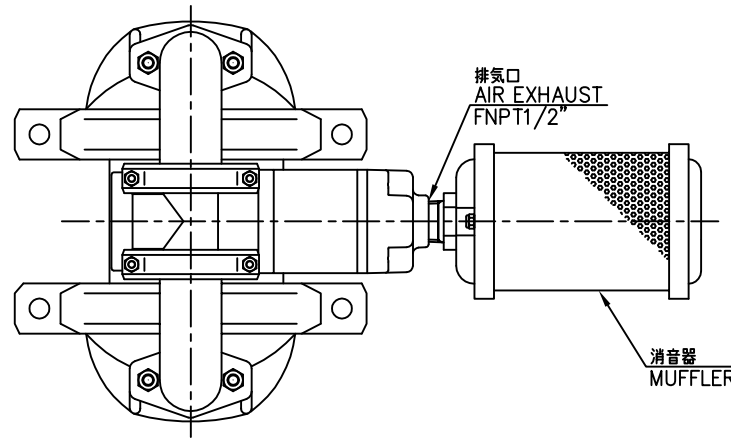
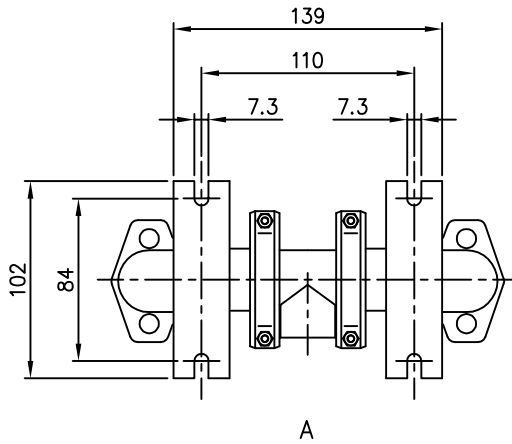

MATERIAL ---	DES. BY		APP. BY	TITLE エアー式ダブルダイヤフラムポンプ WILDEN AIR OPERATED DOUBLE DIAPHRAGM PUMP 型式/MODEL: XPS1 ALUMINUM
SCALE (A3) 1 : 3	DWG. BY D.Sugiyama 20/05/29	APP. BY		
UNITS	JAPAN MACHINERY COMPANY		DRAWING NO. XPS1型 (1/2") アルミニウム	
				REV. MARK 0