

# MODEL XPS1520 METAL PUMP STAINLESS

## 仕様 / Specifications

全高 / HEIGHT	-----	816 mm
全幅 / WIDTH	-----	650 mm
奥行き / DEPTH	-----	728 mm
重量 / SHIP WEIGHT	-----	113 kg
圧縮空気入口 / AIR INLET	-----	FNPT3/4"
排気口 / AIR EXHAUST	-----	FNPT1.1/2"
吸込口 / SUCTION	-----	Rc3"
吐出口 / DISCHARGE	-----	Rc3"

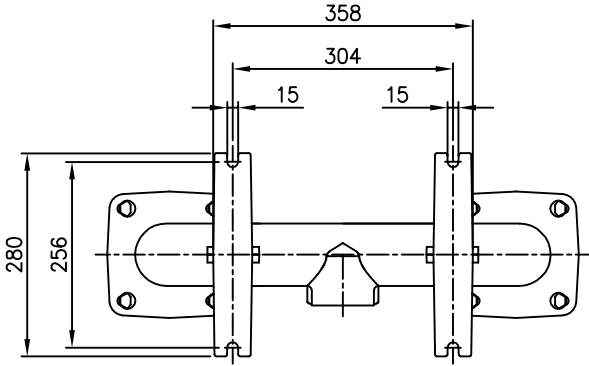

A

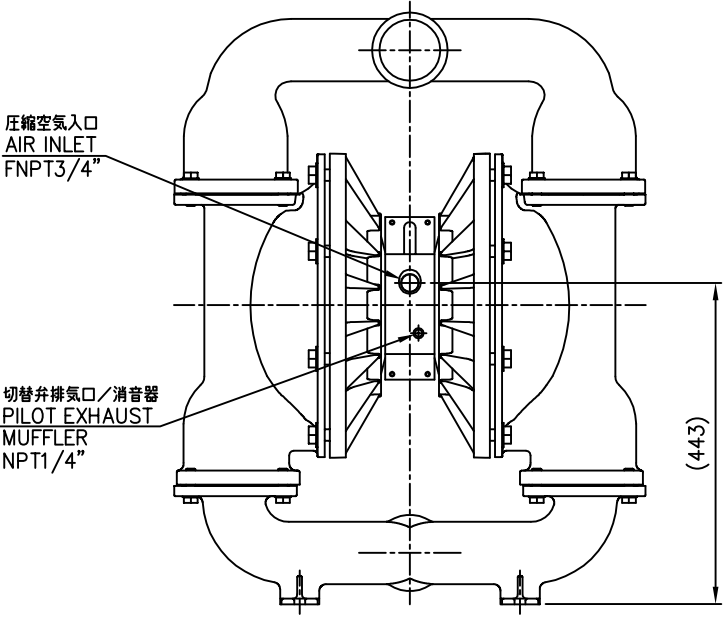
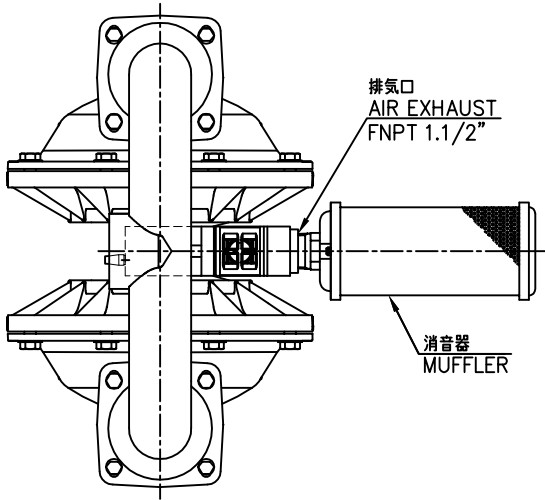

A

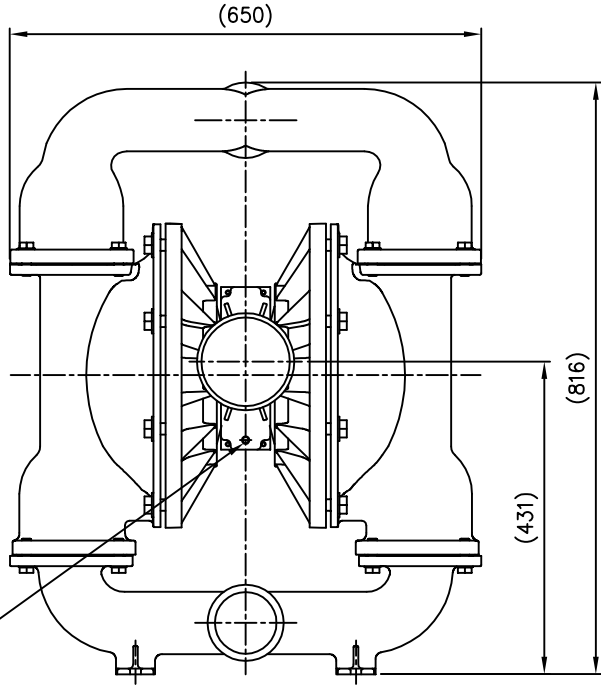
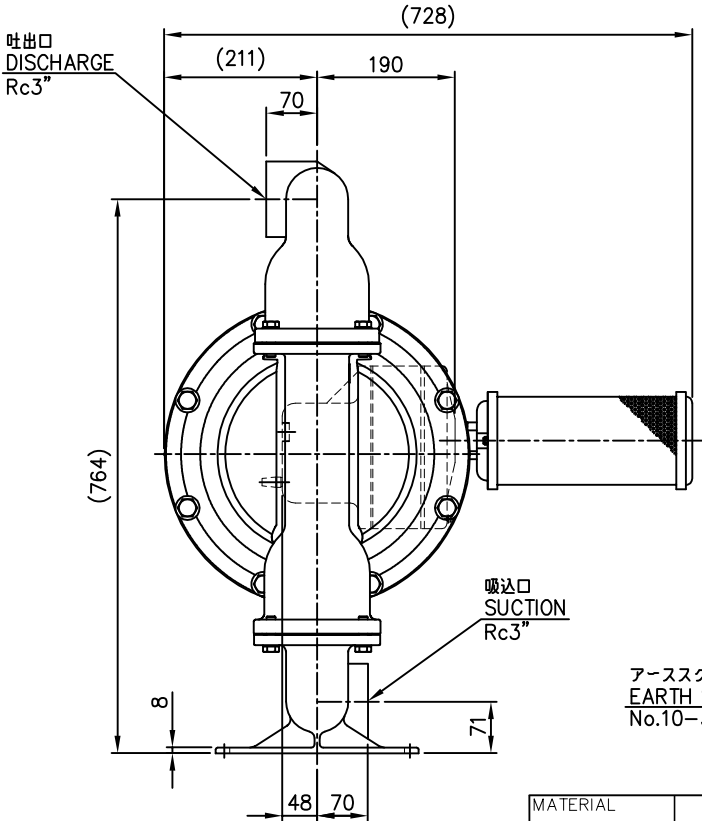

MATERIAL	---			TITLE	エアー式ダブルダイヤフラムポンプ WILDEN AIR OPERATED DOUBLE DIAPHRAGM PUMP 型式/MODEL: XPS1520 STAINLESS	
SCALE	DES. BY	DWG. BY	APP. BY	DRAWING NO. XPS1520型(3") SUS316		
(A3) 1:8		D. Sugiyama 20/05/29				
UNITS	JAPAN MACHINERY COMPANY					